

# **GL G110A**

## **Beam Spot**

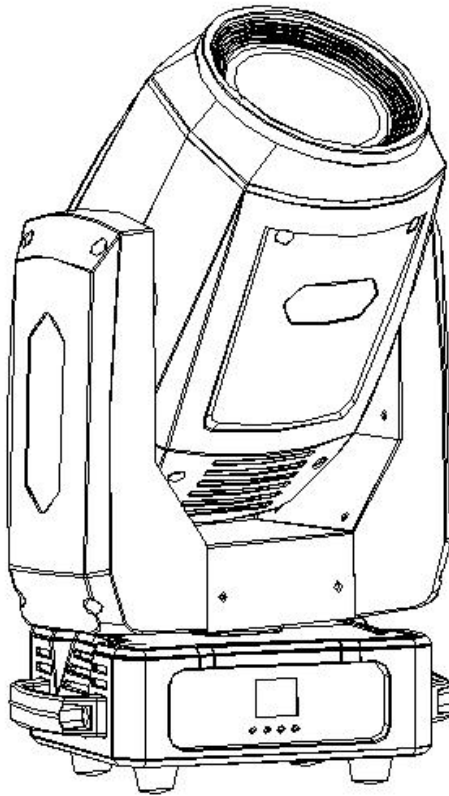

**USER MANUAL**

CP2018100PD.1

# GL 110A Beam Spot

## Table of contents

1.	Safety instructions.....	3
2.	Operating determination.....	4
3.	Fixture exterior view .....	5
4.	Installation .....	6
4.1	Connection to the mains.....	6
4.2	Replacing gobos .....	7
4.3	Rigging the fixture.....	8
4.4	DMX-512 connection.....	11
5.	Control menu map.....	12
6.	Technical Specifications.....	14
7.	Maintenance and cleaning.....	17
8.	Photometric diagram.....	18
9.	DMX protocol.....	19

**CAUTION!**  
***Keep this device away from rain and moisture!***  
***Unplug mains lead before opening the housing!***

**FOR YOUR OWN SAFETY, PLEASE READ THIS USER MANUAL CAREFULLY  
BEFORE YOU INITIAL START - UP!**

## 1. Safety instructions

Every person involved with installation and maintenance of this device have to:

- be qualified
- follow the instructions of this manual

**CAUTION!**  
***Be careful with your operations.***  
***With a high voltage you can suffer***  
***a dangerous electric shock when touching the wires!***

This device has left our premises in absolutely perfect condition. In order to maintain this condition and to ensure a safe operation, it is absolutely necessary for the user to follow the safety instructions and warning notes written in this manual.

### **Important:**

The manufacturer will not accept liability for any resulting damages caused by the non-observance of this manual or any unauthorized modification to the device.

Please consider that damages caused by manual modifications to the device are not subject to warranty.

Never let the power-cord come into contact with other cables! Handle the power cord and all connections with the mains with particular caution!

Make sure that the available voltage is not higher than stated on the rear panel.

WARNING! Always disconnect power input cable to completely remove power from unit when not in use or before cleaning or servicing the unit.

Make sure that the power cord is never crimped or damaged by sharp edges. Check the device and the power-cord from time to time.

Always disconnect from the mains, when the device is not in use or before cleaning it. Only handle the power-cord by the plug. Never pull out the plug by tugging the power cord.

This device falls under protection class I. Therefore it is essential to connect the yellow/green conductor to earth. The electric connection, repairs and servicing must be carried out by a qualified employee.

Do not connect this device to a dimmer pack.

During the initial start-up some smoke or smell may arise. This is a normal process and does not necessarily mean that the device is defective.

Do not touch the device's housing bare hands during its operation (housing becomes hot)!  
For replacement use fuses of same type and rating only.

**Warning! Risk Group 2 LED product according to EN  
62471. LED light emission. Risk of eye injury!**  
**Do not look straight at the fixture's LED source during operation. The intense  
light beam may damage your eyes.**

**Do not view the light output with optical instruments or any device that may concentrate the beam.**

## 2. Operating determination

This device is a moving head for creating decorative effects and was designed for indoor use only. This device is for professional use only. It is not for household use.

If the device has been exposed to drastic temperature fluctuation (e.g. after transportation), do not switch it on immediately. The arising condensation water might damage your device. Leave the device switched off until it has reached room temperature.

Do not shake the device. Avoid brute force when installing or operating the device.

Never lift the fixture by holding it at the projector-head, as the mechanics may be damaged. Always hold the fixture at the transport handles.

When choosing the installation spot, please make sure that the device is not exposed to extreme heat, moisture or dust.

Make sure that the area below the installation place is blocked when rigging, derigging or servicing the fixture.

Always fix the fixture with an appropriate safety rope. Fix the safety rope at the correct holes only.

Only operate the fixture after having checked that the housing is firmly closed and all screws are tightly fastened.

The maximum ambient temperature 45°C must never be exceeded.

### **CAUTION!**

***The lens has to be replaced when it is obviously damaged, so that its function is impaired, e. g. due to cracks or deep scratches!***

Operate the device only after having familiarized with its functions. Do not permit operation by persons not qualified for operating the device. Most damages are the result of unprofessional operation!

Do not block the front objective lens with any object when the fixture is under operation.

The fixture housing never must be covered with cloth or other materials.

Please use the original packaging if the device is to be transported.

Please consider that unauthorized modifications on the device are forbidden due to safety reasons!

If this device will be operated in any way different to the one described in this manual, the product may suffer damages and the guarantee becomes void. Furthermore, any other operation may lead to dangers like short-circuit, burns, electric shock, burns etc.

### **CAUTION!**

***To avoid damage of the internal parts of the fixture head, never let the sunlight or other fixture lights directly to the front lens, even when the fixture is not working!***

### 3. Fixture exterior view

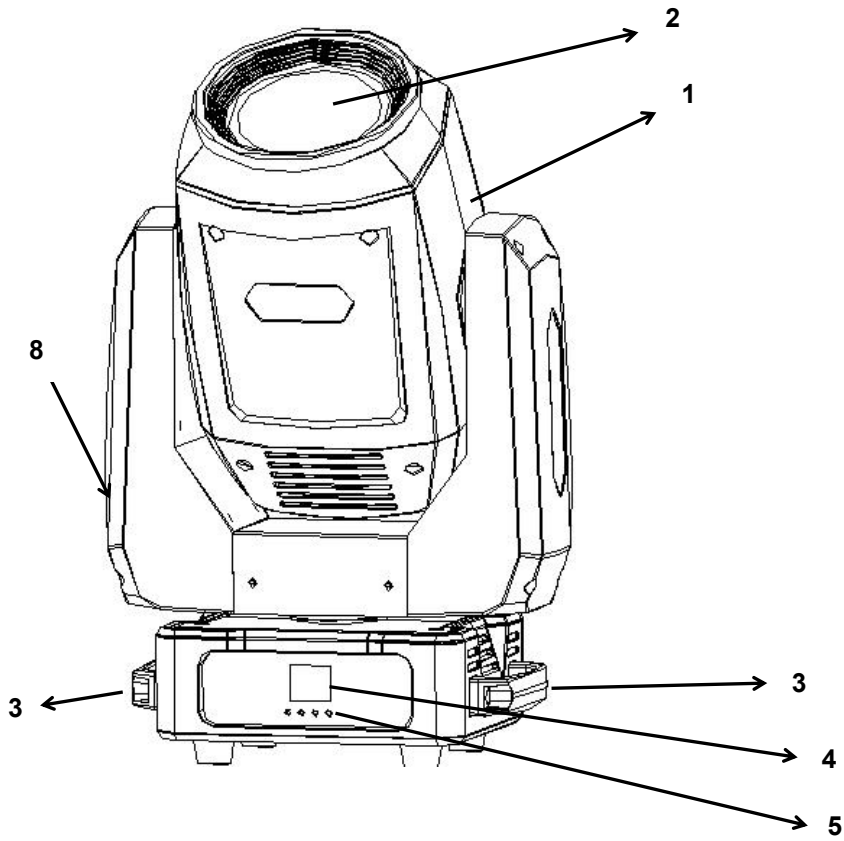

- 1 - Head
- 2 - Front lens
- 3 - Handles
- 4 - Display screen
- 5 - Control buttons
- 6 - Yoke

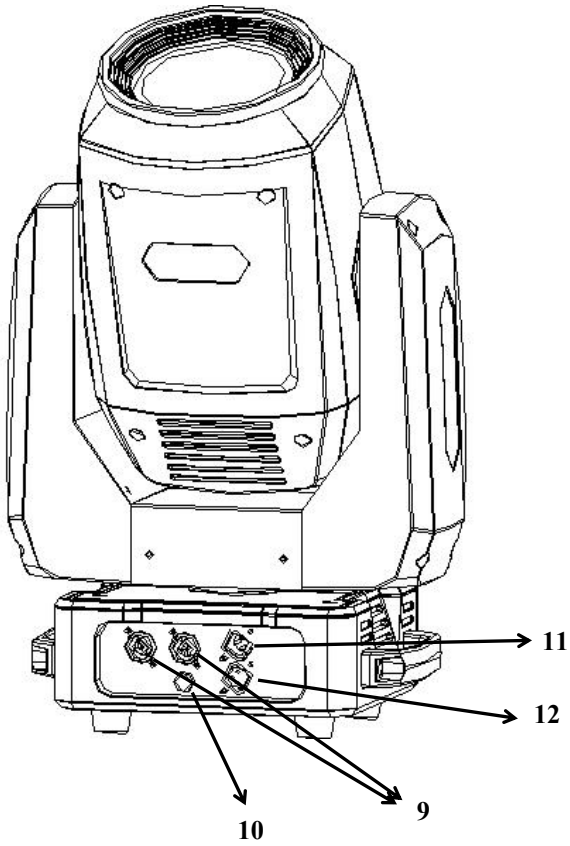

- 9 - Power (PowerCon)
- 10 - Fuse holder
- 11 - DMX OUT (3-pin)
- 12 - DMX IN (3-pin)

## 4. Installation

***Fixtures must be installed by a Qualified electrician in accordance with all national and local electrical and construction codes and regulations.***

### 4.1 Connection to the mains

**For protection from electric shock, the fixture must be earthed!**

For protection from electric shock, the fixture must be earthed!

The GL G110A is equipped with auto-switching power supply that automatically adjusts to any 50-60Hz AC power source from 100-240 Volts. Power cord is enclosed to the fixture.

Install a suitable plug on the power cord if needed, note that the cores in the power cord are coloured according to the following table. The earth has to be connected! If you have any doubts about proper installation, consult a qualified electrician.

Core (EU)	Core (US)	Connection	Plug Terminal Marking
Brown	Black	Live	L
Light blue	White	Neutral	N
Yellow/Green	Green	Earth	

## 4.2 Replacing rotating gobos

**DANGER!**  
**Install the gobos with the device switched off only.**  
**Unplug from mains before!**

1. Disconnect the fixture from mains and allow it to cool.
2. Remove the plastic cover of the head by loosening the 4 quarter-turn fasteners on the cover.
3. Gently pull up the gobo holder (3) from the rotation gobo wheel.
4. Remove the spring lock (1) with an appropriate tool (e.g. small-bladed screwdriver) and remove it. Do not touch the surface of the pattern of the glass gobo with bare fingers.
5. Remove the original gobo (2) and insert the new one (glazy side towards the light source). The Gleelite gobo has a small position point (8) at its edge which has to aimed at the position point (4) on the gobo holder (4). Insert the spring lock to secure correct gobo position in the gobo holder.
6. Insert the gobo holder back under the distance slots (6, 7) into rotating gobo wheel in this way, that its position point (4) has to aimed at a small toothlike projection (5) on the edge of the rotating gobo wheel.

**Important!** When inserting the gobo holder back to the rotating gobo wheel, one of the adjacent gobo holder has to be oriented according to the same rule, it means that its position point (4) has to aimed at the toothlike projection (5) on the edge of the rotating gobo wheel. You have keep both marks (4) and (5) side by side when rotating the gobo wheel to the position allows inserting the gobo holder back.

5. Replace the plastic cover before applying power.

6. Use the menu Service to fine adjust replaced gobo (Service -> Calibration -> Calibrate effects -> R. Gobo Index 1 ...R. Gobo Index 6).

Note. The magnet (9) of the gobo holder has the same function as the position point (4) on the rest of gobo holders.

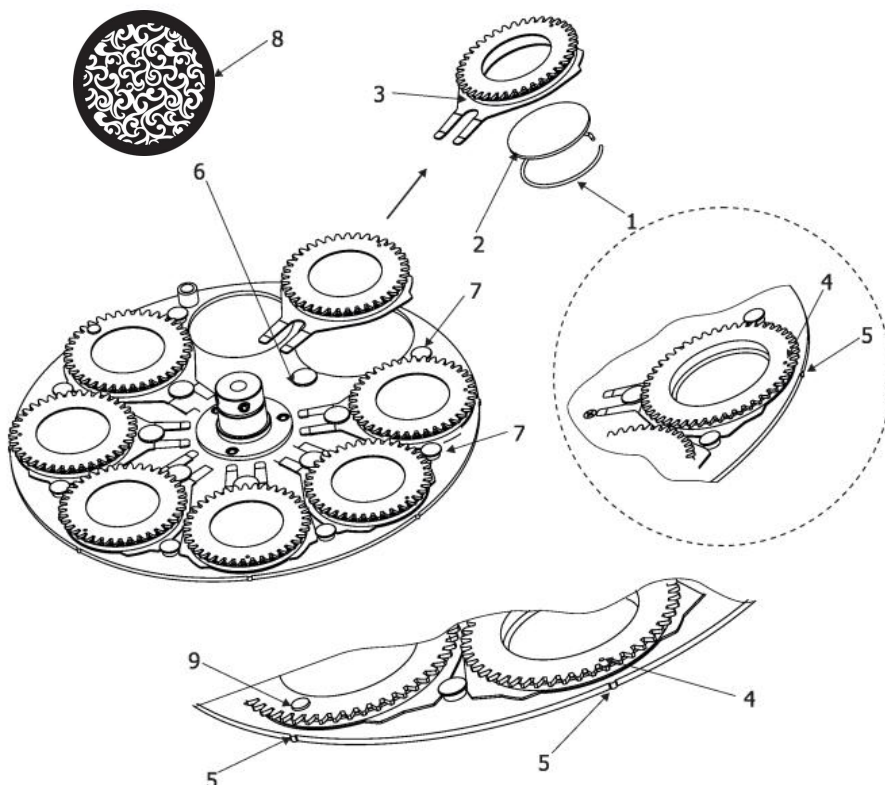

### 4.3 Rigging the fixture

The installation of the fixture has to be built and constructed in a way that it can hold 10 times the weight for 1 hour without any harming deformation.

The installation must always be secured with a secondary safety attachment, e.g. an appropriate catch net. This secondary safety attachment must be constructed in a way that no part of the installation can fall down if the main attachment fails.

When rigging, derigging or servicing the fixture staying in the area below the installation place, on bridges, under high working places and other endangered areas is forbidden.

The operator has to make sure that safety-relating and machine-technical installations are approved by an expert before taking into operation for the first time and after changes before taking into operation another time.

The operator has to make sure that safety-relating and machine-technical installations are approved by an expert after every four year in the course of an acceptance test.

The operator has to make sure that safety-relating and machine-technical installations are approved by a skilled person once a year.

The projector should be installed outside areas where persons may walk by or be seated.

**IMPORTANT! OVERHEAD RIGGING REQUIRES EXTENSIVE EXPERIENCE,** including (but not limited to) calculating working load limits, installation material being used, and periodic safety inspection of all installation material and the fixture. If you lack these qualifications, do not attempt the installation yourself, but instead use a professional structural rigger. Improper installation can result in bodily injury or damage to property.

The fixture has to be installed out of the reach of people.

If the fixture shall be lowered from the ceiling or high joists, professional trussing systems have to be used. The fixture must never be fixed swinging freely in the room.

**Caution:** Fixtures may cause severe injuries when crashing down! If you have doubts concerning the safety of a possible installation, do not install the moving head!

Before rigging make sure that the installation area can hold a minimum point load of 10 times the fixture's weight.

**Danger of fire !**  
**When installing the device, make sure there is no highly inflammable material (decoration articles, etc.) in a distance of min. 0.5 m.**

**CAUTION!**  
**Use 2 appropriate clamps to rig the fixture on the truss. Follow the instructions mentioned at the bottom of the base. Make sure that the device is fixed properly! Ensure that the structure (truss) to which you are attaching the fixtures is secure.**



The fixture can be placed directly on the stage floor or rigged in any orientation on a truss without altering its operation characteristics .  
For securing a fixture to the truss, install a safety wire that can hold at least 10 times the weight of the fixture. Use only the safety wire with screw-on carabine. Pull the safety wire through the safety attachment point on the bottom of the base and around the truss as shown on the pictures below.

### Truss installation

1. Bolt each clamp (1) to the omega holder (3) with M12 bolt and lock nut through the hole in the holder.
2. Fasten the omega holders on the bottom of the base by inserting both quick-lock fasteners (4) into the holes of the base and tighten fully clockwise.
3. Pull the safety wire (2) through the attachment point and around the truss (5).

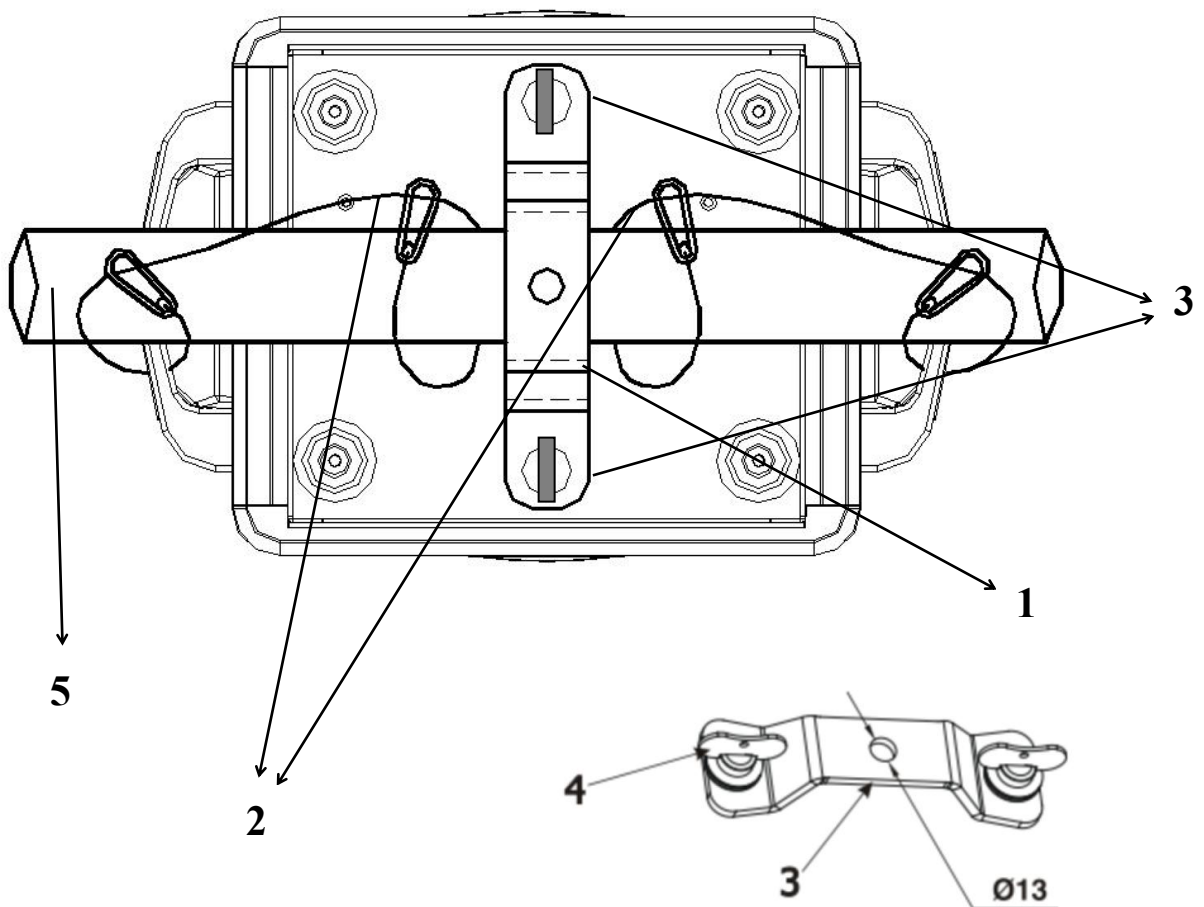

- 1-Clamps
- 2-Safety wire
- 3-Omega holder
- 4-Quick-lock fastener
- 5-truss

Alternatively, fixtures handles can be used for safety attachment

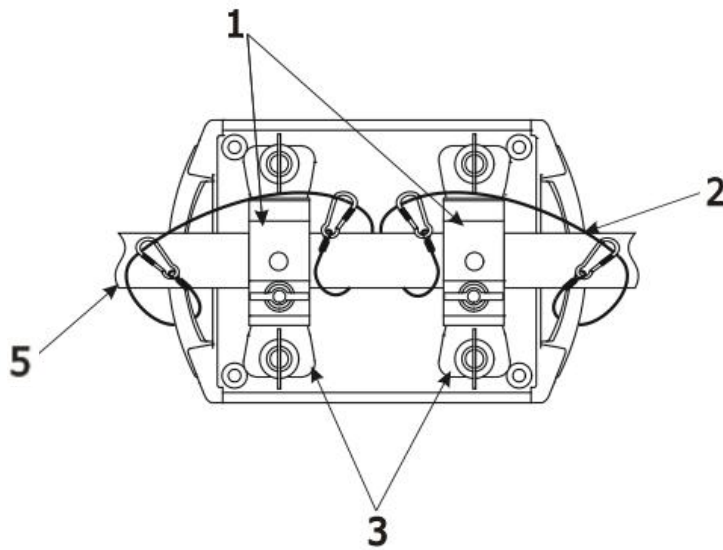

- 1-Clamps
- 2-Safety wire
- 3-Omega holder
- 4-Quick-lock fastener
- 5-truss

**When installing fixtures side-by-side,  
avoid illuminating one fixture with another!**

**DANGER TO LIFE!**  
**Before taking into operation for the first time, the installation has to be  
approved by an expert!**

## 4.4 DMX-512 connection

The fixture is equipped with both 3-pin and 5-pin XLR sockets for DMX input and output. The sockets are wired in parallel.

Only use a shielded twisted-pair cable designed for RS-485 and 3-pin or 5-pin XLR-plugs and connectors in order to connect the controller with the fixture or one fixture with another.

**DMX - output**  
XLR mounting-sockets (rear view):

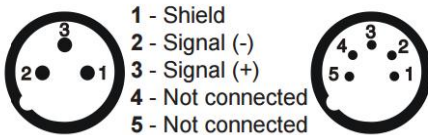

**DMX - input**  
XLR mounting-plugs (rear view):

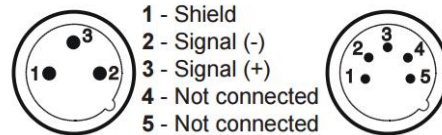

If you are using the standard DMX controllers, you can connect the DMX output of the controller directly with the DMX input of the first fixture in the DMX-chain. If you wish to connect DMX-controllers with other XLR-outputs, you need to use adapter-cables.

**Building a serial DMX-chain:**

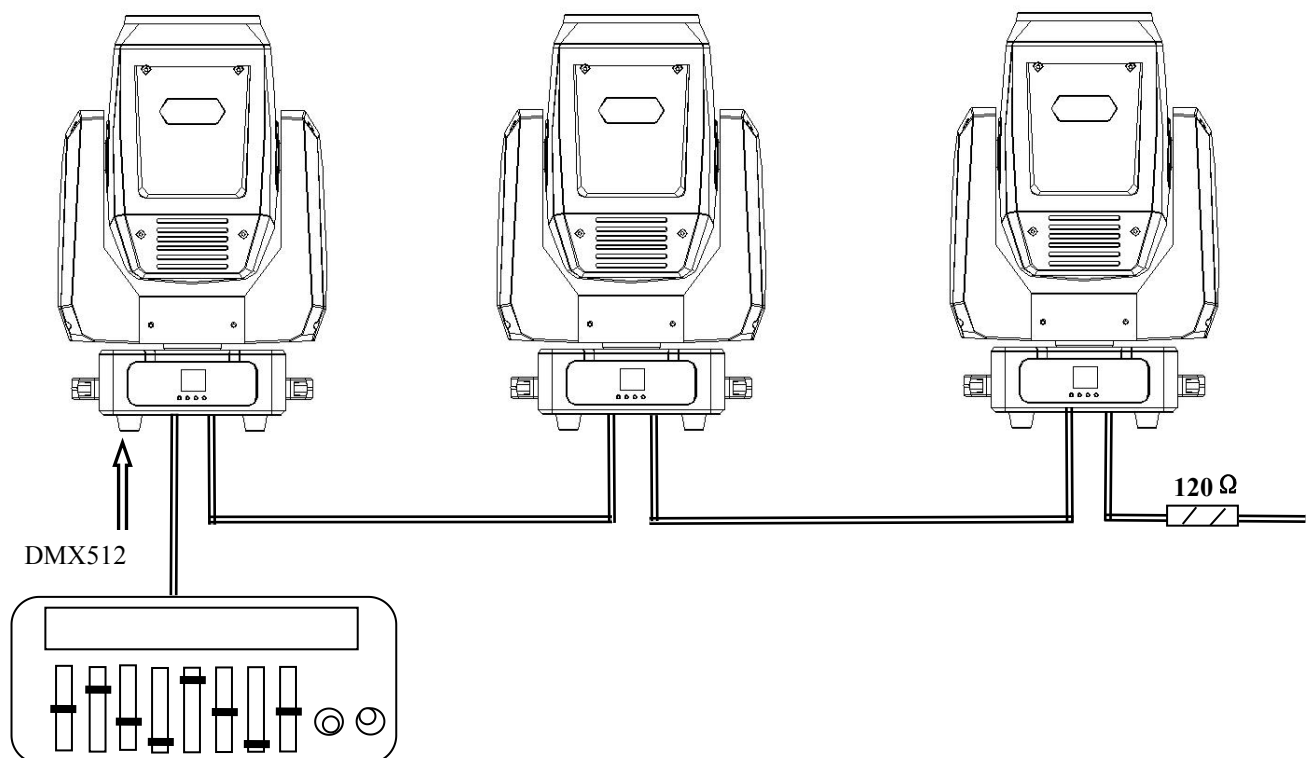

Connect the DMX-output of the first fixture in the DMX-chain with the DMX-input of the next fixture. Always connect one output with the input of the next fixture until all fixtures are connected.

**Caution:** At the last fixture, the DMX-cable has to be terminated with a terminator. Solder a 120  $\Omega$  resistor between Signal (-) and Signal (+) into a 3-pin XLR-plug and plug it in the DMX-output of the last fixture.

## 5. Control menu map

### 1、 Button Instruction

S1: Return 

S2: Down 

S3: UP 

S4: UPEnter 



### Menu Page:

- 1.Address
- 2.Fixture Setting
- 3.Manual Setting
- 4.Auto Test
- 5.System Test
- 6.Information

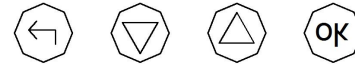

### 2、 Menu Function

**When in Start Page,press any button,then reach the Selection Page**

Main Menu	1 <sup>st</sup> Selection	2 <sup>nd</sup> Selection	Using Noted
Address	Address Setting		a) Press S4 enter to Selection Page; b) Press S2 or S3 to change DMX address at range 1 to 512; c) Press S4 to save and exit Select Page; d) Press S1 to exit directly-without save the selection.
		Channel Mode	Select "Channel Mode" a) Press S4 enter to option selection Page; b) Press S2 or S3 to select Channel Mode options; c) Press S4 to save and exit selection Page; d) Press S1 to exit directly-without save the selection.
Fixture Setting	Pan/Tilt Setting	Invert Pan	Select "Invert Pan/Tilt" a) Press S4 enter to option selection Page; b) Press S2 or S3 to select ON/Off options; c) Press S4 to save and exit the selection Page; d) Press S1 to exit directly-without save the selection.
		Invert Tilt	
		Swap Pan-Tilt	Select "Swap Pan-Tilt" a) Press S4 enter to option selection Page; b) Press S2 or S3 to select ON/Off options; c) Press S4 to save and exit at selection Page; d) Press S1 to exit directly-without save the selection..
Manual	Reset	Head Reset	Select "Reset" a) Press S4 enter to option selection Page; b) Press S2 or S3 to select Reset options; c) Press S4 to save and exit at selection Page; d) Press S1 to exit.
		Pan/Tilt Reset	
		All Reset	
	Channel	Pan	Select "Channel" a) Press S4 enter to channel selection Page; b) Press S2 or S3 to select channel; c) Press S4 to enter edit status; d) Press S2 or S3 to change channel value from 0 to 255 at edit status;
		Tilt	
		Dimmer	
		Strobe	
Color	e) Press S4to save channel value and exit edit status;		
Fixed-Gobo	f) Press S1 to exit edit status without save.		
Rot-Gobo			

		Rot-Gobo Rot	
		Prism	
		Prism Rot.	
		Focus	
		Zoom	
<b>Auto Test</b>	Stop		Select "Auto Test" a) Press S4 enter to test program Page; b) Press S2 or S3 to select test program options; c) Press S4 to save and run selected test program; d) Press S1 to exit without save .
	Test program 1		
	Test program 2		
	Test program 3		
<b>System</b>	Language	Chinese	Select "Language" a) Press S4 enter to option selection Page; b) Press S2 or S3 to select Language options; c) Press S4 to save and exit to selection Page; d) Press S1 to exit without save.
		English	
	Backlight Setting	Auto	Select "Backlight Setting" a) Press S4 enter to option selection Page; b) Press S2 or S3 to select Backlight Setting options; c) Press S4 to save and exit selection Page; d) Press S1 to exit without save.
		Keep On	
	Display	Normal	Select "Display" a) Press S4 enter to option selection Page; b) Press S2 or S3 to select Display options; c) Press S4 to save and exit selection Page; d) Press S1 to exit without save.
		Turnover	
	Factory Reset	Ok	
Cancel			
<b>Main Menu</b>	<b>1<sup>st</sup> Selection</b>	<b>2<sup>nd</sup> Selection</b>	<b>Using Noted</b>
<b>Address</b>	Address Setting		a) Press S3 enter to Selection Page; b) Press S2 or S4 to change DMX address at range 1 to 512; c) Press S3 to save and exit Select Page; d) Press S1 to exit directly-without save the selection.
<b>Fixture Setting</b>	Channel Mode	Standard Mode	Select "Channel Mode" a) Press S3 enter to option selection Page; b) Press S2 or S4 to select Channel Mode options; c) Press S3 to save and exit selection Page; d) Press S1 to exit directly-without save the selection.
		Reduced Mode	
		Extend Mode	
	Pan/Tilt Setting	Invert Pan	Select "Invert Pan/Tilt" a) Press S3 enter to option selection Page; b) Press S2 or S4 to select ON/Off options; c) Press S3 to save and exit the selection Page; d) Press S1 to exit directly-without save the selection.
		Invert Tilt	
		Swap Pan-Tilt	
	Curve	Curve 1	Select "Curve" a) Press S3 enter to option selection Page; b) Press S2 or S4 to select Dimmer Curve options;
Curve 2			
Curve 3			

		Curve 4	c) Press S3 to save and exit at selection Page; d) Press S1 to exit directly-without save the selection.	
		Curve 5		
<b>Manual</b>	Reset	Head Reset	Select "Reset"	
		Pan/Tilt Reset	a) Press S3 enter to option selection Page;	
		All Reset	b) Press S2 or S4 to select Reset options; c) Press S3 to save and exit at selection Page; d) Press S1 to exit.	
	Channel	Pan	Select "Channel"	a) Press S3 enter to channel selection Page; b) Press S2 or S4 to select channel; c) Press S3 to enter edit status; d) Press S2 or S4 to change channel value from 0 to 255 at edit status; e) Press S3 to save channel value and exit edit status; f) Press S1 to exit edit status without save.
		Tilt		
		Dimmer		
		Strobe		
		Color		
		Fixed-Gobo		
		Rot-Gobo		
		Rot-Gobo Rot		
		Iris		
		Effect		
		Effect Rot		
Focus				
<b>Auto Test</b>	Stop		Select "Auto Test"	
	Test program 1		a) Press S3 enter to test program Page;	
	Test program 2		b) Press S2 or S4 to select test program options;	
	Test program 3		c) Press S3 to exit at selection UI with save and run selected test program; d) Press S1 to exit without save .	
<b>System</b>	Language	Chinese	Select "Language"	
		English	a) Press S3 enter to option selection Page; b) Press S2 or S4 to select Language options; c) Press S3 to save and exit to selection Page; d) Press S1 to exit without save.	
	Backlight Setting	Auto	Select "Backlight Setting"	
		Keep On	a) Press S3 enter to option selection Page; b) Press S2 or S4 to select Backlight Setting options; c) Press S3 to save and exit selection Page; d) Press S1 to exit without save.	
	Display	Normal	Select "Display"	
		Turnover	a) Press S3 enter to option selection Page; b) Press S2 or S4 to select Display options; c) Press S3 to save and exit selection Page; d) Press S1 to exit without save.	
<b>Information</b>			Select "Information"	
			a) Press S3 enter to view system information; b) Press S1 to return main menu.	

## 6. Technical Specifications

### Electrical

Power supply:.....electronic auto-ranging  
Input voltage range:..... 100-240V, 50/60Hz  
Max. power consumption:.....152 W@230V  
Fuse:.....T 5 A

### Light source

100W white engine  
Colour temperature: 8500K  
CRI=70  
Colour wheel  
13 dichroic filters + open

### Static gobo wheel

19 metal gobos, image diameter =5mm, aluminium,  
thickness=0.5 mm  
Gobo wheel continuous rotation

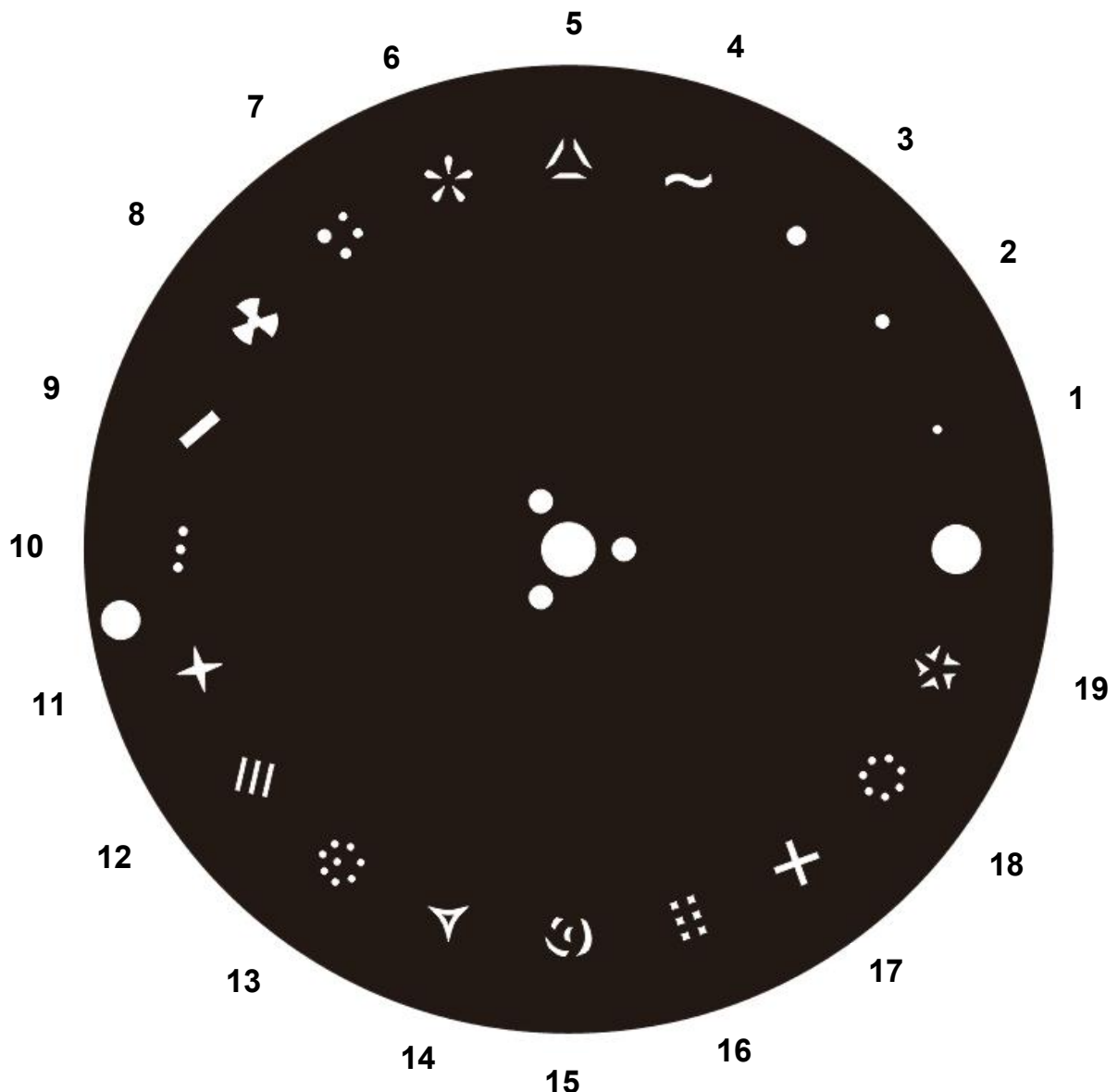

## Rotating gobo wheel

8 glass gobos can be indexed and rotated in both directions at different speeds Gobo wheel continuous rotation  
Glass gobos: outside diameter=12 mm, max. thickness=3 mm, high temperature borofloat or better glass  
"Slot&lock" system for easy replacement of gobos

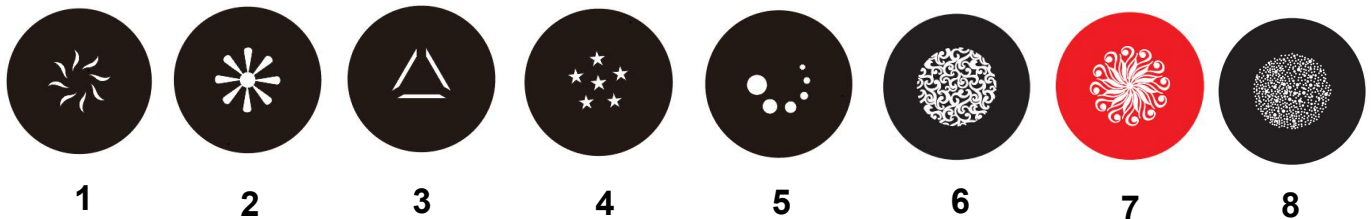

**Warning!!!**  
***All glass Gobos which needed change, must be supply from the original factory. These glass gobos are professional heat-resistant glass Gobos. Or we would not be providing any warranty for them!***

### Prism

Rotating 8-facet 11° prism with continuous rotation in both directions

### Iris

Motorized iris for different beam diameters

### Zoom

Linear motorized zoom (2.5°- 20°)

### Strobe

Strobe effect with variable speed (max.15 flashes/sec.)

### Dimmer

Smooth dimmer from 0 - 100 %

### Control

Readout fixture and light source usage, receiving DMX values, temperatures, etc  
Built-in analyzer for easy fault finding, error messages  
Built-in demo sequences  
Black-out while head moving, colour changing  
Silent fans cooling,



## Optional Wireless DMX/RDM module

Compliance with USITT DMX-512 (1986 & 1990) and 512-A  
Full DMX fidelity and frame integrity  
Auto sensing of DMX frame rate and frame size  
<5ms DMX latency  
Operational frequency range of 2402-2480 MHz

## Pan/Tilt

Pan movement range 540°  
Tilt movement range 270°  
16 bit movement resolution

## Rigging

Mounting points: 1 of 1/4-turn locks  
Mounting horizontally or vertically via 1 Omega brackets

## Temperatures

Maximum ambient temperature : 45° C  
Maximum housing temperature : 80° C

## Minimum distances

Min. distance from flammable surfaces: 0.5 m  
Min. distance to lighted object: 2 m

**Weight (net) 12 kg**

**Dimensions (mm)**

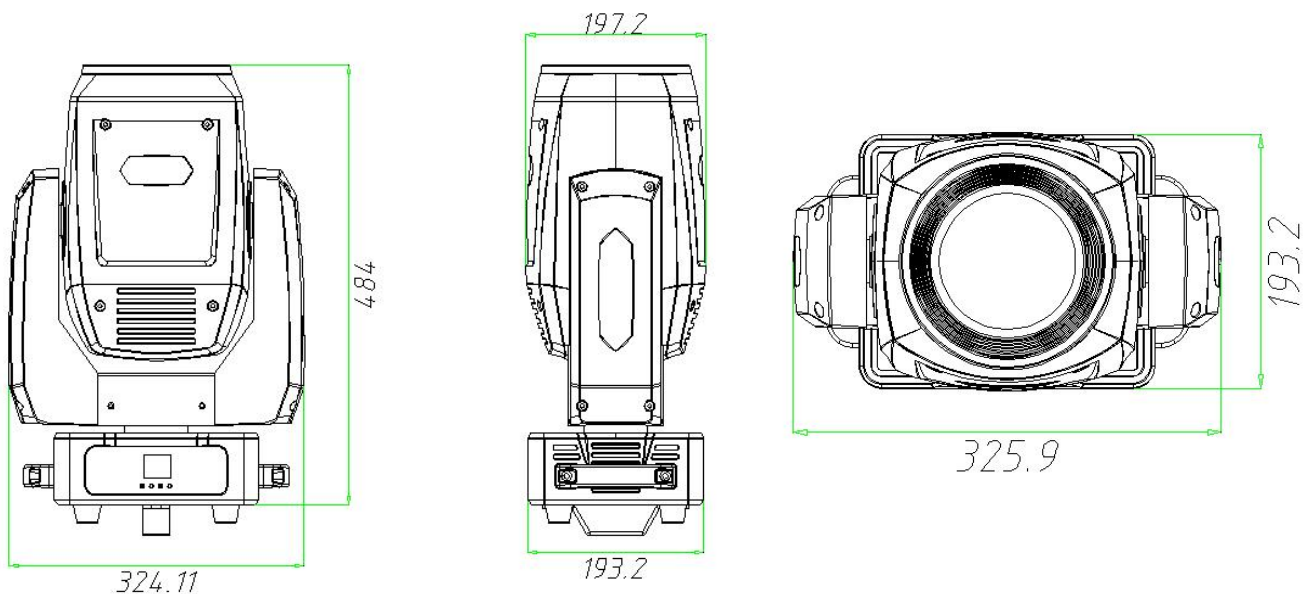

## 7. Maintenance and cleaning

It is absolutely essential that the fixture is kept clean and that dust, dirt and smoke-fluid residues must not build up on or within the fixture. Otherwise, the fixture's light-output will be significantly reduced. Regular cleaning will not only ensure the maximum light-output, but will also allow the fixture to function reliably throughout its life. A soft lint-free cloth moistened with any good glass cleaning fluid is recommended, under no circumstances should alcohol or solvents be used!

***DANGER !***  
***Disconnect from the mains before starting any maintenance work***

The front objective lens will require weekly cleaning as smoke-fluid tends to building up residues, reducing the light-output very quickly. The cooling-fans should be cleaned monthly.

The interior of the fixture should be cleaned at least annually using a vacuum-cleaner or an air-jet. Dichroic colour filters, gobo wheels and the internal lenses should be cleaned monthly.

Remove dust and dirt from the fans and cooling vents using a soft brush and vacuum-cleaner.

***Important!***  
***Check the air filters periodically and clean before they become clogged!***

Clean the air filters placed in the fixture bases. Use a vacuum cleaner, compressed air or you can wash them and put back dry.

After replacing the air filters, reset the elapsed time counter in the menu "Information" (Information--->Air Filters---> Elapsed Time).

### **Replacing the fuse.**

Before replacing the fuse, unplug mains lead.

- 1) Remove the fuse holder on the rear panel of the base with a fitting screwdriver from the housing (anti-clockwise).
- 2) Remove the old fuse from the fuse holder.
- 3) Install the new fuse in the fuse holder (only the same type and rating).
- 4) Replace the fuseholder in the housing and fix it.

### **12.1 Disposing of the product**

To preserve the environment please dispose or recycle this product at the end of its life according to the local regulations and codes.

## **8. Photometric diagram**

20° Brightness(LX)	2560	950	640
2.5° Brightness(LX)	100400	39200	14300

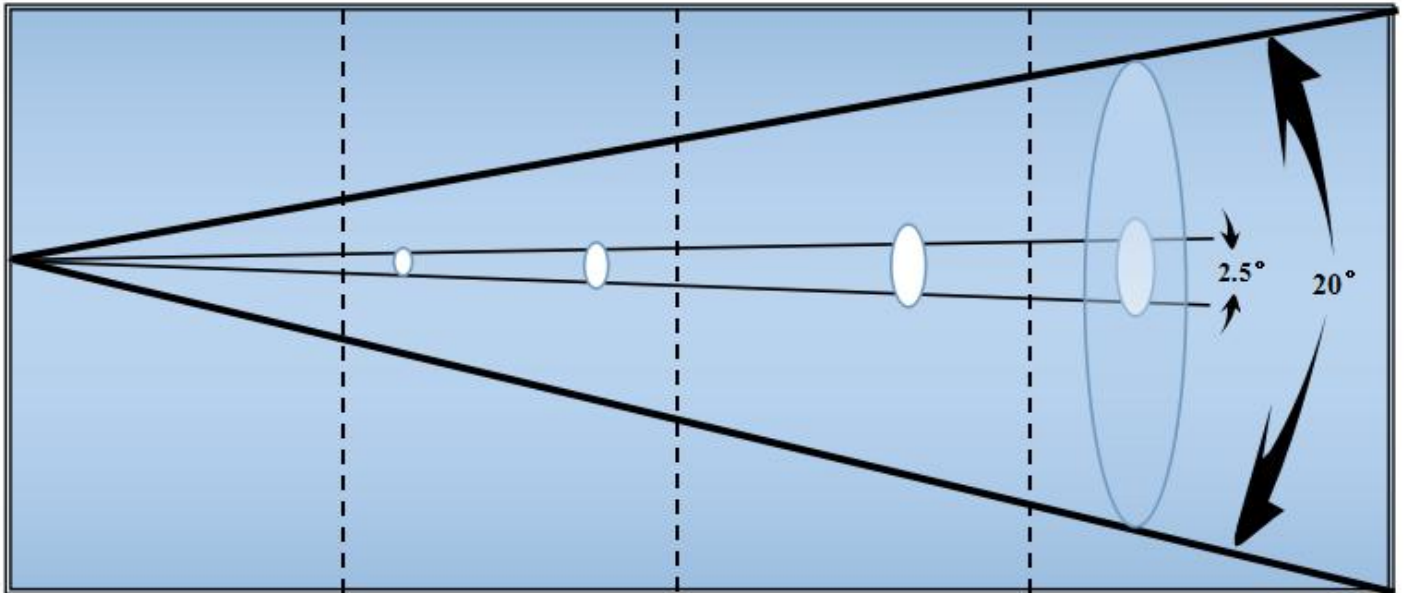

Distance(M)	3	5	8
20° Spot diameter(CM)	113	175	260
2.5° Beam diameter(CM)	14	23	37

## 9. DMX protocol

### GLG80 DMX Channel

Mode/Channel		Value	Function
St	Ba		
1	1	0-255	Pan 0-100%
2		0-255	Pan fine 0-100%
3	2	0-255	Tilt 0-100%
4		0-255	Tilt fine 0-100%
5	3	0-255	Pan/Fine Speed Fast -> Slow
6	4	0-255	Dimmer 0 -> 100%
7			Dimmer Fine 0 -> 100%
8	5	252-255 213-251 208-212 108-207 104-107 4-103 0-3	Strobe/Shutter Open Random Strobe Open Pulse: Slow -> Fast Open Strobe: Slow -> Fast Close
9	6	213-255 170-212 167-169 164-166 161-163 158-160 155-157 152-154 149-151 146-148 143-145 140-142 137-139 134-136 131-133 128-130 0-127	Color1 Wheel Rotation(CCW):Slow -> Fast Rotation(CW): Fast -> Slow Open Color13 Color12 Color11 Color10 Color9 Color8 Color7 Color6 Color5 Color4 Color3 Color2 Color1 Color Position
10		0-255	Color1 Wheel fine 0 -> 100%

11	7	234-255 212-233 204-211 196-203 188-195 180-187 172-179 164-171 156-163 148-155 140-147 132-139 124-131 116-123 108-115 100-107 92-99 84-91 76-83 68-75 60-67 57-59 54-56 51-53 48-50 45-47 42-44 39-41 36-38 33-35 30-32 27-29 24-26 21-23 18-20 15-17 12-14 9-11 6-8 3-5 0-2	<b>Static Gobo</b> Rotation(CCW): Slow -> Fast Rotation(CW): Slow -> Fast Gobo19 Shake: Slow -> Fast Gobo18 Shake: Slow -> Fast Gobo17 Shake: Slow -> Fast Gobo16 Shake: Slow -> Fast Gobo15 Shake: Slow -> Fast Gobo14 Shake: Slow -> Fast Gobo13 Shake: Slow -> Fast Gobo12 Shake: Slow -> Fast Gobo11 Shake: Slow -> Fast Gobo10 Shake: Slow -> Fast Gobo9 Shake: Slow -> Fast Gobo8 Shake: Slow -> Fast Gobo7 Shake: Slow -> Fast Gobo6 Shake: Slow -> Fast Gobo5 Shake: Slow -> Fast Gobo4 Shake: Slow -> Fast Gobo3 Shake: Slow -> Fast Gobo2 Shake: Slow -> Fast Gobo1 Shake: Slow -> Fast Gobo19 Gobo18 Gobo17 Gobo16 Gobo15 Gobo14 Gobo13 Gobo12 Gobo11 Gobo10 Gobo9 Gobo8 Gobo7 Gobo6 Gobo5 Gobo4 Gobo3 Gobo2 Gobo1 Open
----	---	--	---

12	8	194-255 132-193 120-131 108-119 96-107 84-95 72-83 60-71 48-59 42-47 36-41 30-35 24-29 18-23 12-17 6-11 0-5	<b>Rotating Gobo</b> Rotation(CCW): Slow -> Fast Rotation(CW): Slow -> Fast Gobo7 Shake: Slow -> Fast Gobo6 Shake: Slow -> Fast Gobo5 Shake: Slow -> Fast Gobo4 Shake: Slow -> Fast Gobo3 Shake: Slow -> Fast Gobo2 Shake: Slow -> Fast Gobo1 Shake: Slow -> Fast Gobo7 Gobo6 Gobo5 Gobo4 Gobo3 Gobo2 Gobo1 Open
13	9	193-255 128-192 0-128	<b>Gobo Rotation</b> Gobo Rotation(CCW): Slow -> Fast Gobo Rotation(CW): Fast -> Slow Gobo Position
14	10	128-255 0-127	<b>Prism</b> Prism Open
15	11	194-255 190-193 128-189 0-127	<b>Prism Rotation</b> Prism Rotation(CCW): Slow -> Fast Prism Static Prism Rotation(CW): Fast -> Slow Prism Position
16	12	0-255	<b>Focus</b> 0 -> 100%
17		0-255	<b>Focus Fine</b> 0 -> 100%
18	13	0-255	<b>Zoom</b> 0 -> 100%
19		0-255	<b>Zoom Fine</b> 0 -> 100%
20	14	201-255 151-200 100-150 0-99	<b>System Control</b> All reset Head reset Pan and tilt reset Unused

**If you have any questions, please contact your local dealer**

CP2018100PD.2